

PASCAA Certification Certificate



Applicant company name.....
Contact Name.....
Address.....
.....
Phone.....
Fax.....
Email.....
Website

Certification Results

1. Minimum Gauge Test
PASCAA Test Method TM-1001
 - a. PASCAA Minimum requirement total thickness at selvedge and between bubbles 400 microns
Test Result..... fail (under 400um) pass (400um or above)
Test performed by (laboratory).....
 - b. PASCAA minimum requirement thickness measured anywhere on product
Test Result..... fail (under 90um) pass (90um or above)
Test performed by (laboratory).....
2. Tensile Strength
Test Method ASTM D 412
Test Result..... fail (under 15 MPa) pass (15MPa or above)
Test performed by (laboratory).....
3. Tear Strength
Test Method ASTM 1938
Test Result..... fail (under 35N) pass (35N or above)
Test performed by (laboratory).....
4. Puncture Resistance
Test Method ASTM D 1709 Falling Dart Impact Test
Test Result..... fail (under 700 grams) pass (700 grams or above)
Test performed by (laboratory).....
5. Light Exposure Performance Criteria
4 weeks exposure to AS 2001.4.21 (known as MBTF light barrel test)
Samples tested before and after exposure for breaking force and elongation to AS 2001.2.3.2 in machine direction and cross direction
 - a. Tensile strength – no more than 10% braking force loss MD or CD after MBTF exposure
Test Result..... fail (over 10%) pass (10% or under)
Test performed by (laboratory).....
 - b. Elongation – no more than 65% loss of elongation in MD or CD after MBTF exposure
Test Result..... fail (over 65%) pass (65% or under)
Test performed by (laboratory).....
6. Buoyancy
Test Method PASCAA TM-1002
Test Result..... fail (under 1.5lit/m2) pass (1.5lit/m2 or above)
Test performed by (laboratory).....
7. Thermal Performance
Test Method ISO 9302 Guarded Hot Plate
Test Result..... fail (under 0.05m2K/W) pass (0.05m2K/W or above)
Test performed by (laboratory).....
8. Lamination
Test Method AS 4201.1 Dry Delamination
Test Result..... fail pass
Test performed by (laboratory).....

All tests must be carried out by an independent NATA approved testing facility. MBTF test to be carries out by AWTA, Flemington VIC.

PASCAA automatic fit for propose certification with 8 authorized passes above with supporting testing documentation attached

PASCAA POOL COVER MINIMUM SPECIFICATIONS

Gauge

Blanket total layer thickness at selvedge and between bubbles : 400 micron
Minimum thickness measured anywhere on the product : 90 micron

Test Method : PASCAA TM -1001

Tensile Strength

Recommendation : Minimum 15MPa
Test Method : ASTM D 412

Tear Strength

Recommendation : Minimum 35N
Test Method : ASTM 1938

Puncture Resistance

Method : ASTM D1709 Falling dart impact test
Recommendation : Minimum 700 grams

Light exposure Performance Criteria

4 weeks exposure to AS 2001.4.21 (known as MBTF light barrel test)
Samples tested before and after exposure for breaking force and elongation to AS 2001.2.3.2 in machine direction and cross direction

No more than 10% breaking force loss MD or CD after MBTF exposure
No more than 65% loss of elongation in MD or CD after MBTF exposure

Type of stabilizers used.

A letter from the stabilizer Manufacturer stating their product contains no materials harmful to health (eg no heavy metals, PCB's etc).

Buoyancy

Recommendation: 1.5lit/m² Minimum buoyancy (displaced volume/m²)

Test Method : PASCAA TM-1002

Warranty

The blanket must be protected by a written warranty covering a minimum four year period. The warranty shall be :

12 months repair or replace
Pro-rated year by year for the remaining 3 years

Thermal Performance (R value)

ISO 8302 Guarded Hot Plate

Minimum R Value $0.05\text{m}^2\text{K/W}$

Lamination

Recommendation : Pass.

Test Method : AS 4201.1 Dry Delamination.

Note all tests must be carried out by an independent NATA approved testing facility. MBTF test to be carried out by AWTA, Flemington, Vic.

March 1, 2010

PASCAA TEST METHOD TM-1002

BOUYANCY TEST

Equipment

250cc graduated measuring cylinder.
300mm Rule
Laboratory balance
Thermometer

Conditions

23C +/-1C

Method.

Determine bubble density. Measure the centre distance between 10 bubbles in each of the machine and cross directions. Record as D1 and D2 (in mm). The values are generally different for each direction. Note that these measurements are to be taken at right angles to each other.

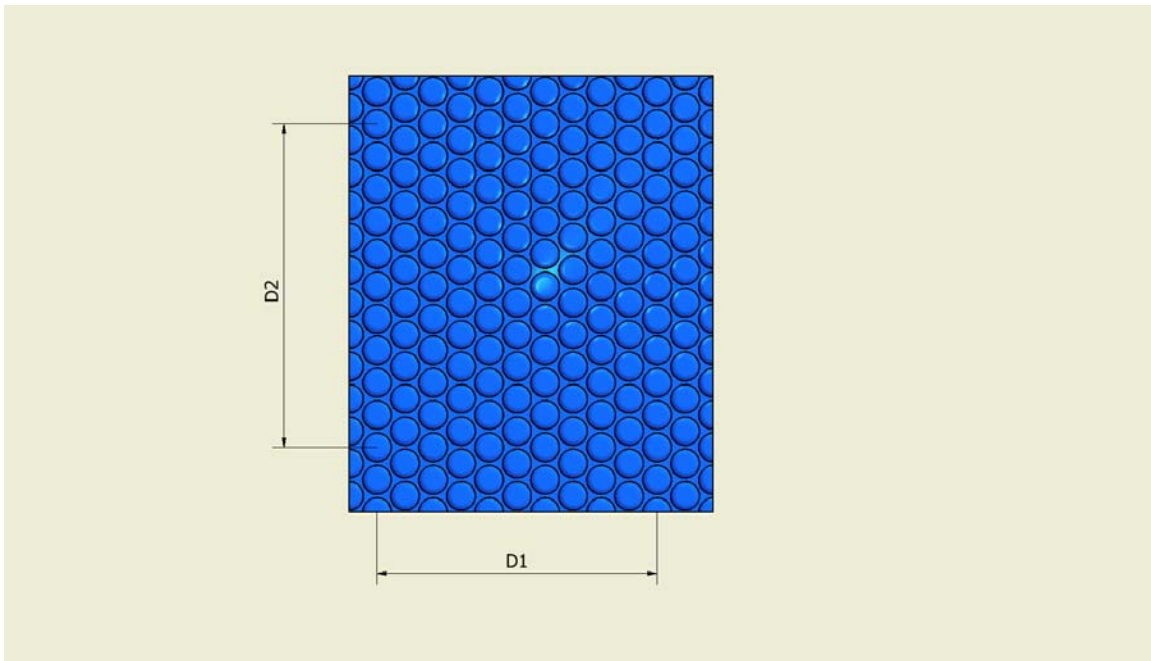

The number of bubbles per square metre is

$$N = \frac{100,000,000}{D1 \times D2}$$

Cut a 125 x 125mm sample of the test material. Remove bubbles at the edge that are cut through as per photo below. Count the number of full bubbles in the specimen and record as B. Weigh the sample and record as W (gm).

Fill the measuring cylinder with water to a depth of approximately 150mm (so it is greater than the sample to be tested). The water must be between 22-24C when the readings are taken. Record the first reading to the nearest cc as V1 (cc).

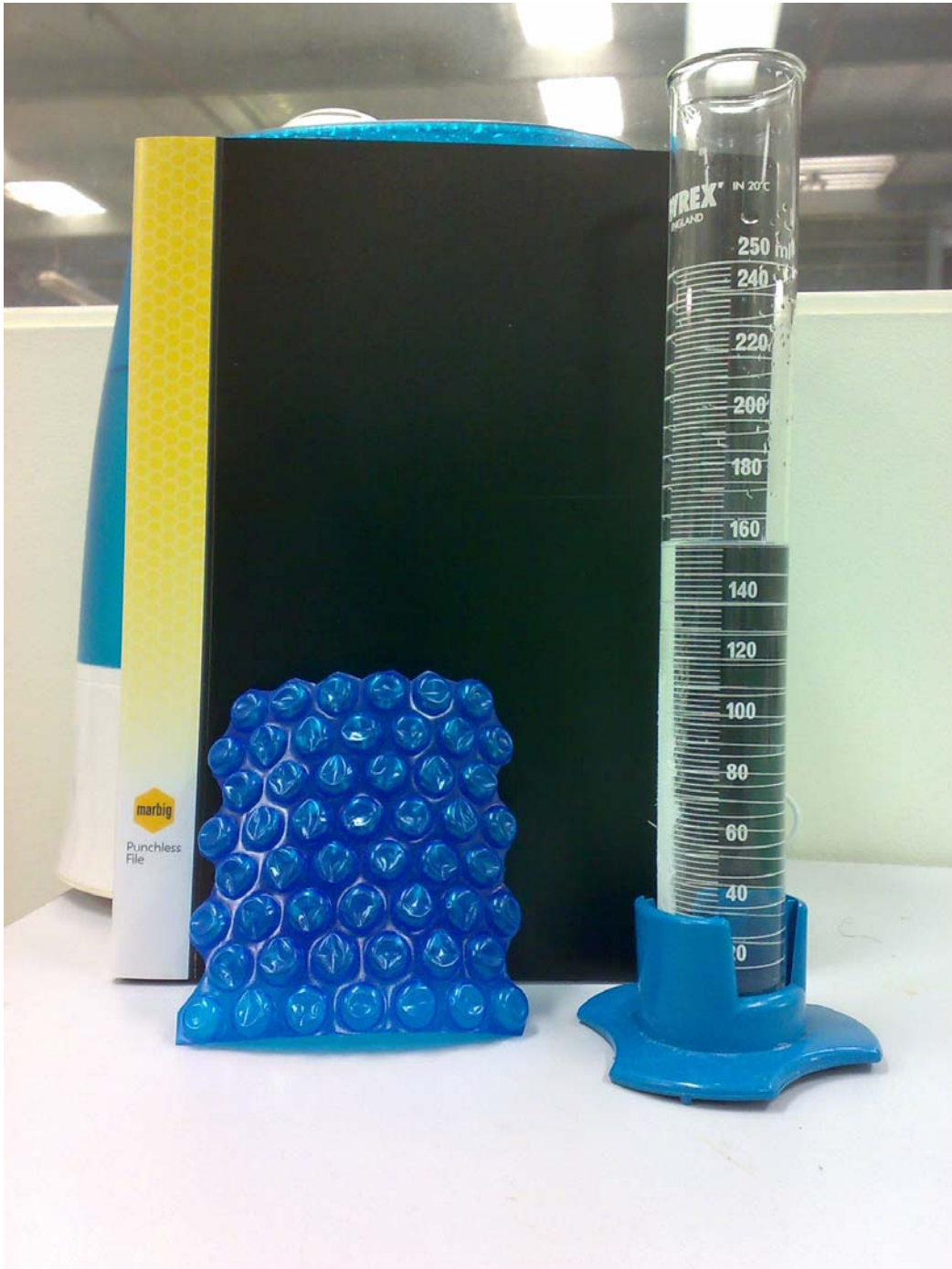

Fully submerge the sample in the water and ensure that there are no bubbles trapped on the surface of the material. Record the reading of the new volume of liquid including the sample as V2 (cc). The displaced volume of air in the sample material is V2-V1-W

The unit displacement per square metre or buoyancy is:

$$\frac{N \times (V2-V1-W)}{B \times 1000} \quad \text{lit/m}^2$$

The minimum pass value is 1.5 lit/m²

March 1, 2010.

PASCAA TEST METHOD TM-1001

MINIMUM GAUGE TEST

Equipment

Digital Micrometer with 3 micron accuracy or better fitted with 2.5mm dia tip and foot with 3.5mm dia ball. Measuring force 1.5N. Use of a cable release as shown below is recommended.



Sample

Full width of bubble material, 100mm wide.

Preparation of test specimen

Condition samples in controlled atmosphere 23C +/- 1 for 2hrs

Method

Cut ten bubbles at even spacing across the sample. Cut the top off the bubble and measure the thickness around the bubble in locations shown in Fig 1. Move the bubble piece around the micrometer tips to find the minimum thickness anywhere on the bubble. This is normally found in the corner of the bubble (location B). Check the flat side D of the bubble also in case it is a lower reading than A, B or C. Take the average of the 10 readings and report that as the result.

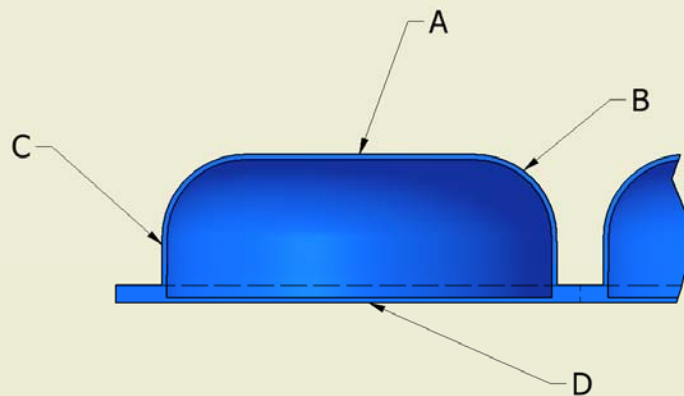

Figure 1

Result

The average minimum value must be equal to or greater than 90 microns to pass the test.

March 1, 2010